



TOPOSENS

Toposens Processing Unit

For usage in combination with the Toposens ECHO ONE® 3D Ultrasonic Echolocation and Ranging Sensor



Data Sheet V1.0 | 07/2022

The content of this document is subject to change without notice.
The most recent version of this document can be found at toposens.com/downloads

1. Technical Data

Mechanical

Dimensions	112 x 84 x 25 mm
Weight	450 g
Enclosure Material	Aluminum housing
Mounting Options	M3 Threads, DIN-Rail (optional)

Environmental

Ambient Temperature Range	-40° to 80° C
Cooling Solution	Passive, no cooling-fan
Ingress Protection	Use in dry conditions only

Electrical

Nominal Supply Voltage	12 V DC
Operating Voltage Range	8-36 V DC
Current Consumption typ. (12 V)	300 mA with TS Point Cloud Processing running and Ethernet up
Peak Current Consumption (12 V)	1 A
Power Consumption avg. (12 V)	4 W
Peak Power Consumption (12 V)	12 W

Connectivity

Ethernet	1x 1000Mbps Ethernet port, RJ45 connector 1x 100Mbps Ethernet port, RJ45 connector
CAN Bus	1x CAN BUS, 1 Mbps (In use for Sensor Bus)
CAN Bus termination	Internally switchable, 120 Ohms
Digital Inputs (EN 61131-2)	4x Voltage Input, 8-24V, 3mA, isolated, Phoenix connector

Digital Outputs (EN 61131-2)	4x Voltage Source, max. 0.5A, isolated, Phoenix connector
USB	3x USB2.0 ports, type-A connector

Compliance

EMC	<ul style="list-style-type: none"> - FCC 47CFR part 15: 2015 – Class B - VCCI-CISPR 32: 2016 - ICES-003: 2017 – Class B - EN 55032: 2015 - Class B - EN 61000-6-3: 2007 - EN 61000-3-2: 2014 - EN 61000-3-3: 2013 - EN 61000-6-2: 2019 - EN 55035: 2017
Safety	- IEC/EN/UL/CSA 62368-1: 2014
Declaration of conformity	CE, FCC, RoHS
MTTF	>200,000 hrs

2. Dimensions

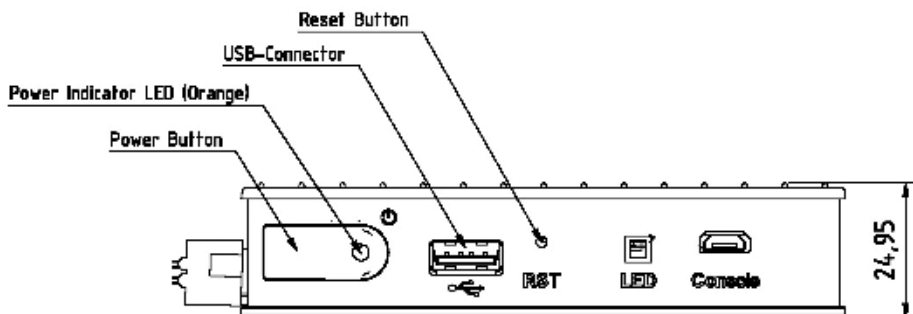
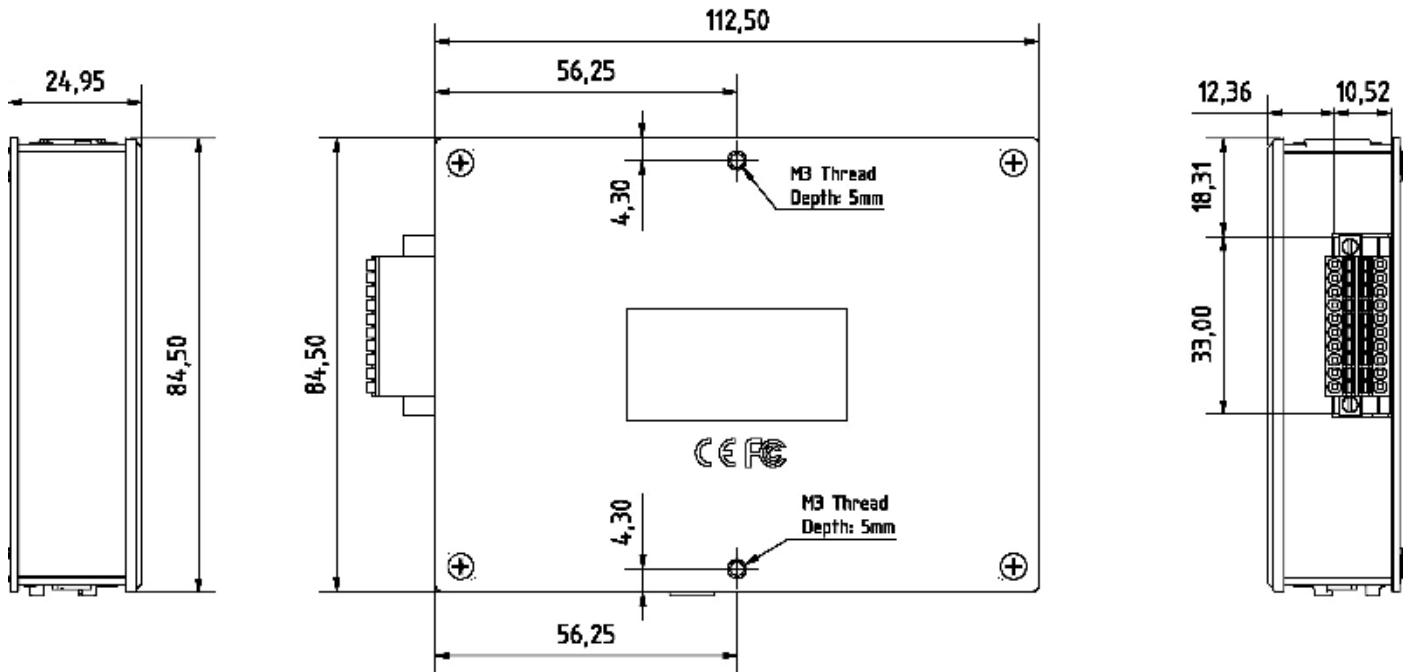
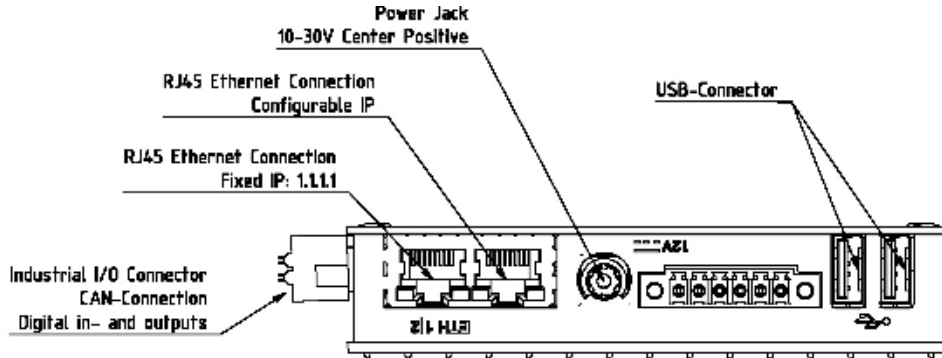

3. Pinout – I/O Connector

Industrial I/O Connector

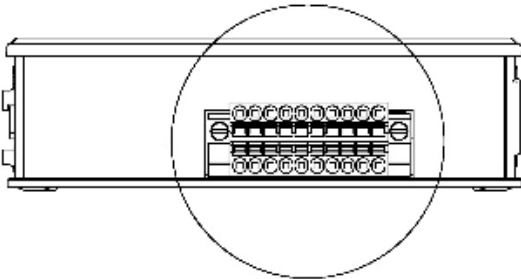

Industrial I/O Connector Detail View

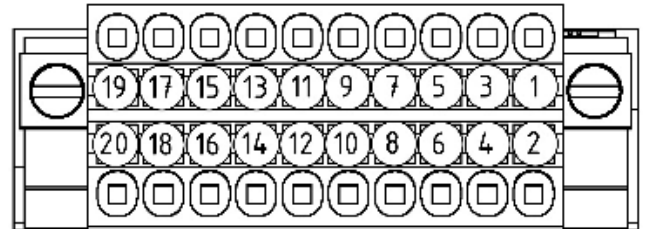

Pin No.	Function
1	CAN High
2	CAN Ground + Shield
3	CAN Low
4	NC
5	NC
6	NC
7	Reserved – Do not connect
8	Reserved – Do not connect
9	Reserved – Do not connect
10	NC
11	Zone violation Output – Stop Zone (Voltage Output, max. 0.5A)
12	Zone violation Output – Zones free (Voltage Output, max 0.5A)
13	Zone violation Output – Warning Zone (Voltage Output, max 0.5A)
14	Reserved – Do not connect
15	Zone deflection Input – Left Turn (Active High, 8-24V, 3mA typ.)
16	Zone expansion Input – High Speed (Active High, 8-24V, 3mA typ.)
17	Zone deflection Input – Right Turn (Active High, 8-24V, 3mA typ.)
18	Reserved – Do not connect
19	+ Vlogic (12-24V DC)
20	I/O (Logic) GND

4. I/O Wiring

Toposens Processing Unit: I/O-Wiring

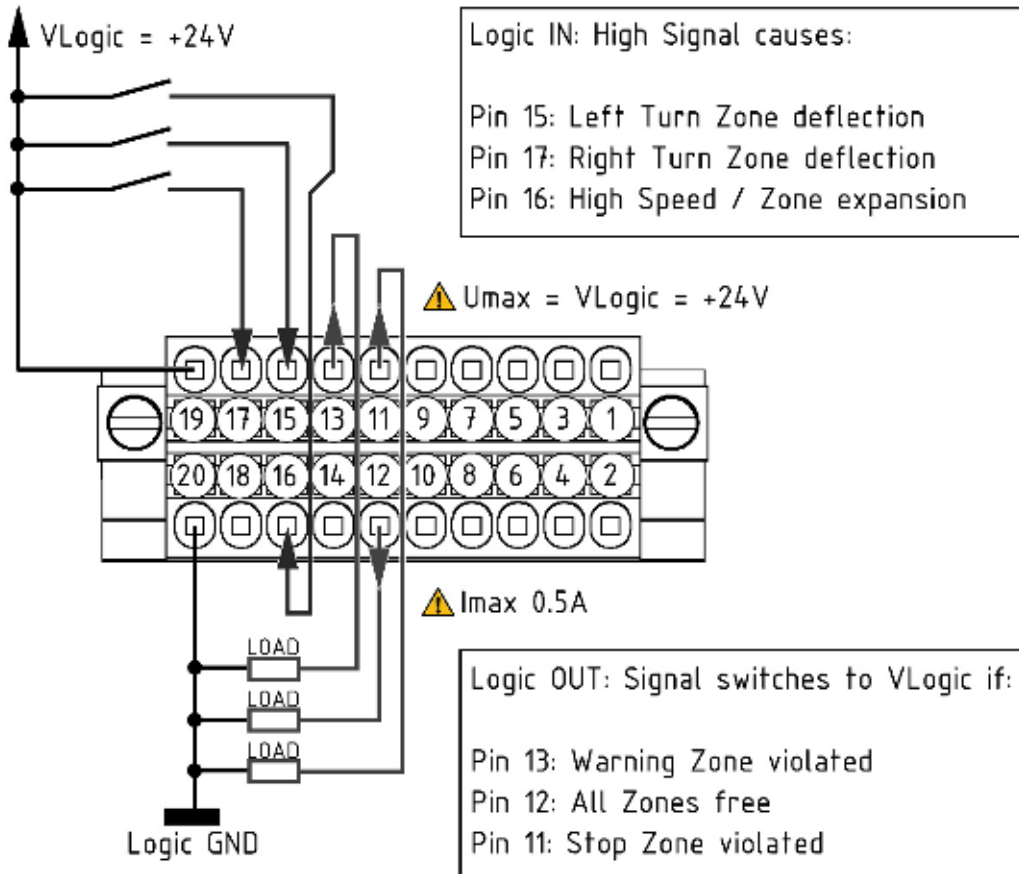

5. System Connection

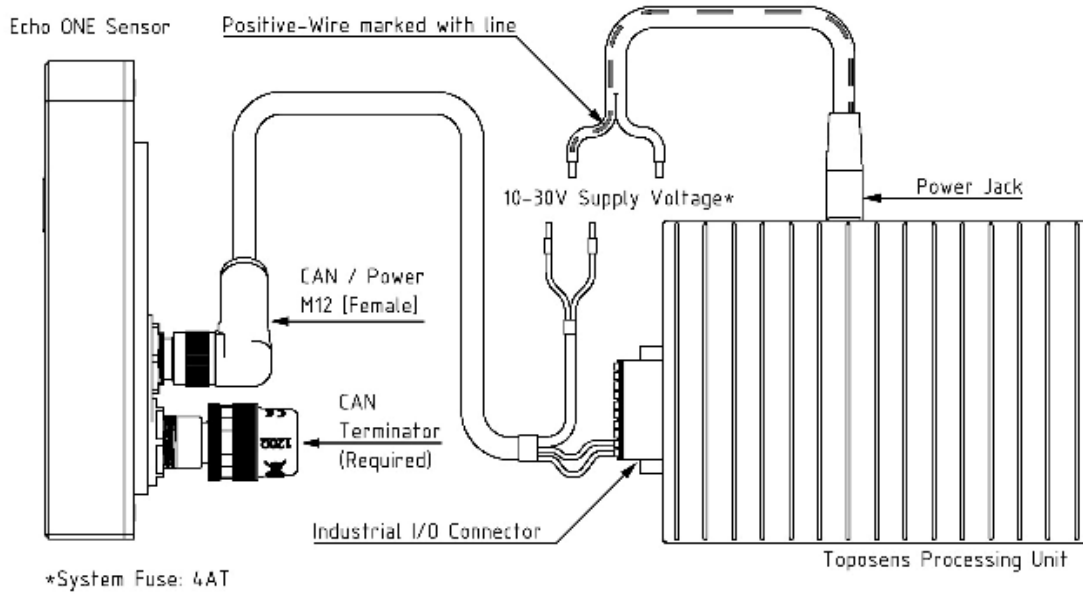

6. Sensor Bus

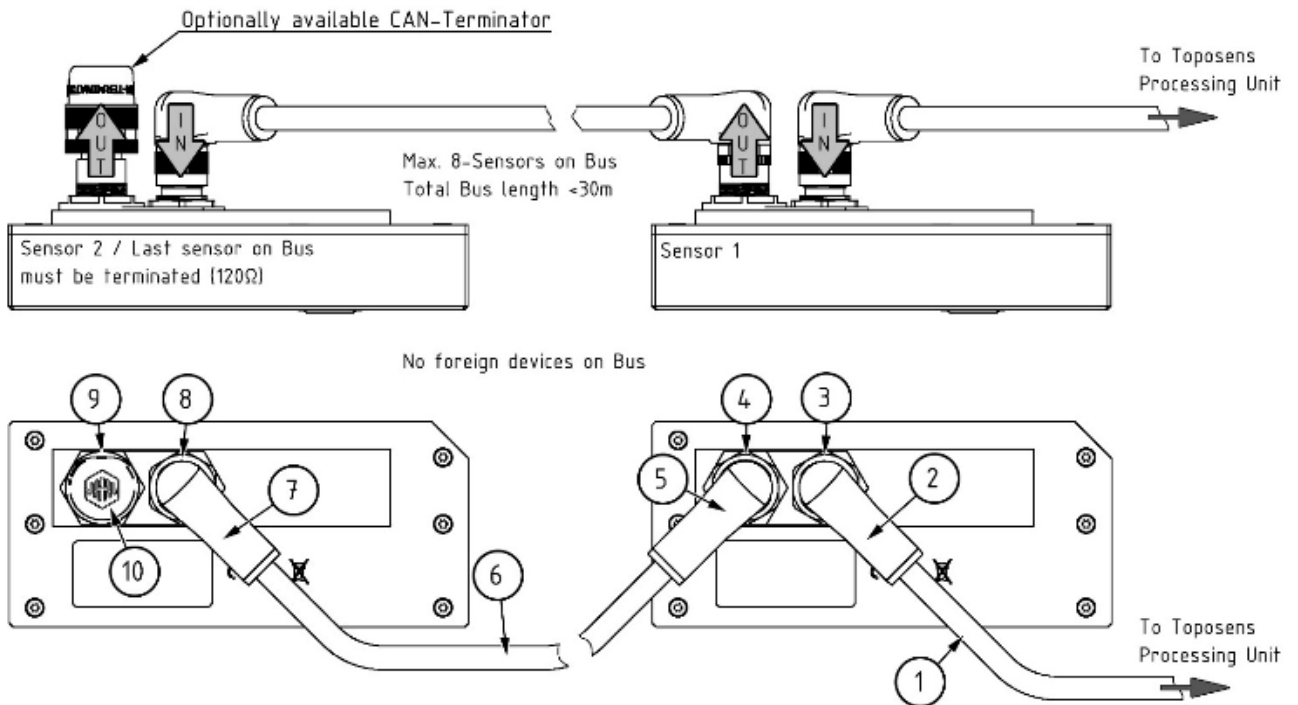

Number	Part Name
1	Cable to Toposens Processing Unit
2	M12 A-Coded 8-Pin Female Cable Connector
3	M12 A-Coded 8-Pin Male Sensor Connector
4	M12 A-Coded 8-Pin Female Sensor Connector
5	M12 A-Coded 8-Pin Male Cable Connector
6	Cable between Echo ONE sensors
7	M12 A-Coded 8-Pin Female Cable Connector
8	M12 A-Coded 8-Pin Male Sensor Connector
9	M12 A-Coded 8-Pin Female Sensor Connector
10	M12 Terminator Male

7. Pinout – ECHO ONE®

Sensor Connectors

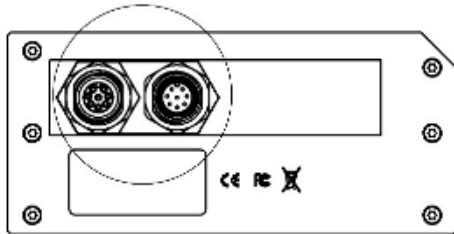

Sensor Connectors: Detail View

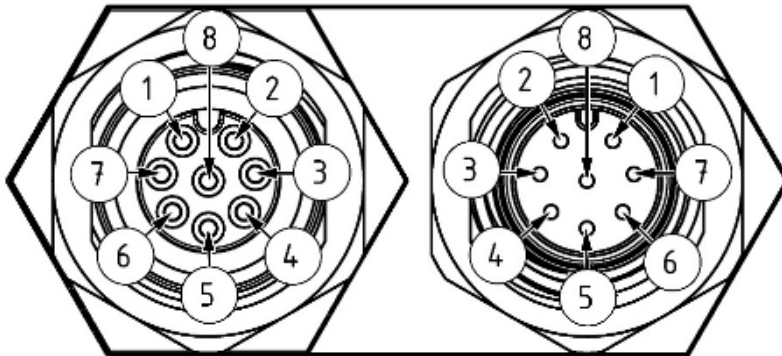

M12 A-Coded 8-Pin Female

M12 A-Coded 8-Pin Male

Pin No.	Function
1	+Vin
2	+Vin
3	Reserved / Connect to Shield
4	Reserved / Connect to Shield
5	-Vin / PGND
6	CAN_L
7	CAN_H
8	-Vin / PGND
Case/Shield	CAN GND / Shield

Pin No.	Function
1	+Vout (Fused)
2	+Vout (Fused)
3	Reserved / Connect to Shield
4	Reserved / Connect to Shield
5	-Vout / PGND
6	CAN_L
7	CAN_H
8	-Vout / PGND
Case/Shield	CAN GND / Shield

Toposens GmbH

Lyonel-Feininger-Straße 28
80807 Munich

www.toposens.com

+49 (0) 89 23751540

Document Version: 1.0
Release Date: July 2022

Toposens reserves the right to change specifications and information in this document without notice.